

PLAN VIEW

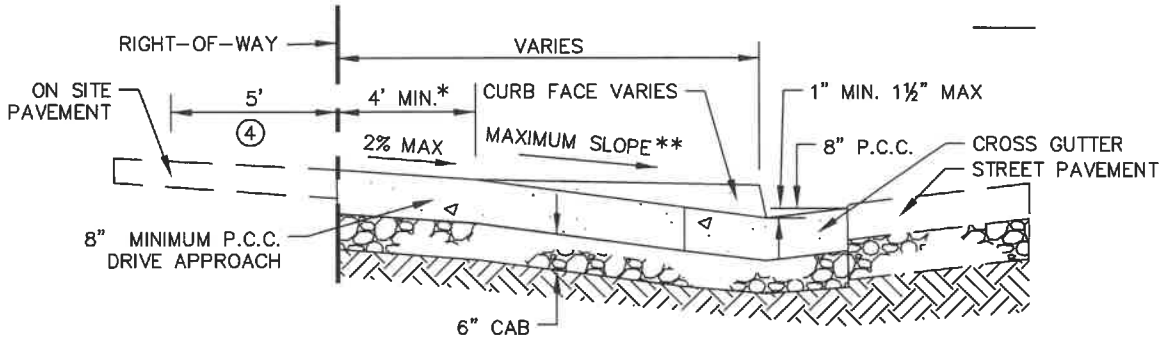

SECTION A-A

- * 4' MINIMUM SIDEWALK IS NOT REQUIRED IF SIDEWALK SHALL BE CONSTRUCTED BEYOND THE RIGHT-OF-WAY (SEE NOTE # 4).
- ** MAXIMUM SLOPE= 10% FOR 8" CURB FACE AND 8.33% FOR 6" CURB FACE. SLOPE MAY BE INCREASED TO 12% WITH CITY ENGINEER APPROVAL.

NOTES

- ① CURB RETURN RADII VARIES ACCORDING TO PARKWAY WIDTHS AND COMMERCIAL VEHICLE TYPE OR AS APPROVED BY THE CITY ENGINEER.
- ② COMMERCIAL DRIVE APPROACH SHALL BE USED FOR ALLEY ENTRANCE UNLESS OTHERWISE APPROVED BY THE CITY ENGINEER.
- ③ BCR & ECR OF APPROACH SHALL NOT BEGIN CLOSER THAN 5' FROM PROPERTY LINE AND A MINIMUM OF 20' FROM A STREET CURB RETURN OR AS REQUIRED BY THE CITY OF ONTARIO ACCESS GUIDELINES.
- ④ 5' WIDE PUBLIC EASEMENT MAY BE REQUIRED FOR CONSTRUCTION OF SIDEWALK BEYOND THE RIGHT OF WAY.
- ⑤ CONCRETE SHALL BE CLASS 520-C-2500 PER SECTION 201 OF THE STANDARD SPECIFICATIONS FOR PUBLIC WORKS CONSTRUCTION, CURED WITH TYPE 1-D CURING COMPOUND.
- ⑥ COMMERCIAL DRIVE APPROACH SHALL BE POURED MONOLITHICALLY UNLESS OTHERWISE APPROVED BY THE CITY ENGINEER.



APPROVED BY:		62809 <i>8-25-21</i>	
KHOI DO, CITY ENGINEER	RCE	DATE	
RECOMMENDED:		70990 <i>8/19/21</i>	
BROWN LIRLEY, PRINCIPAL ENGINEER	RCE	DATE	
REV	DESCRIPTION	BY	APP'D DATE

CITY OF ONTARIO	
COMMERCIAL DRIVEWAY APPROACH	STANDARD DRAWING NUMBER 1204